

NOTES

- 1 "SAFE AREA" is a safe area under all conditions and would normally be on surface.
- 2 Maximum radio frequency power is:
SAFE AREA: 1000mW (134-1000 MHz)
Hazardous Area: 100mW (134-200 MHz)
- 3 Non IS equipment is located in the SAFE AREA and is powered from a power source not exceeding 25V rms which is derived through a double wound transformer from an AC supply not exceeding 250 V rms, 47-63 Hz. This AC supply has battery backup for 24 hours operation minimum.
- 4.1 Interconnection between the Safe Area and the Hazardous Area is only made through a Barrier Unit Type BAR.
- 4.2 Barrier Unit type BAR are also used to create DC "Cells" which have a single DC power source.
- 5 Each Cell has a maximum of one nominal 12V DC IS Power Supply type PSU. PSU to be installed in fresh air area of mine.
- 5.1 Only an MSHA approved Intrinsically Safe power supply as specified in Sheet 2 of this drawing may be used.
- 5.2 PSU must be installed in compliance with Sheet 2 of this drawing.
- 6 Power is only supplied to each cell from PSU through the Power Coupler type DPC and Splice Unit type SPL. Each cell has a maximum of one DPC.
- 7 All units are interconnected (except as specified in Note 5.2 above) through separately MSHA approved leaky feeder (LF) cable, p.n RNG-500 (SLYWV-75-10). Maximum length of LF cable between units is 600m. Minimum length of LF cable between units is 2 m. RNG-500 cable has the following specifications:

 Inner Conductor size: 1 conductor x 2.31 +/-0.05 mm diameter
 Outer Conductor size: 16 strands x 0.6 +/- 0.05 mm diameter
 Maximum voltage: 48 Vrms
 L/R ratio: 45.09 uH/ohm
 Capacitance: 51 +/- 2 pF/m
- 8 A passive Stope Antenna Type ANT may be connected in place of any STR.
- 9 The arrangement of the units in a typical Cell may be varied to suit a particular application provided that:

 9.1 Power is only supplied to the cell through the DPC and SPL units as shown;
 9.2 There is a maximum of nine AMI units;
 9.3 There are a maximum of ten STR, ten SPX and ten ANT units.
 9.4 There is no limit to the number of SPL units in a cell. The SPL unit is used to splice together two sections of Leaky Feeder cable.
- 10 There may be any number of Cells, provided that each complies with certification requirements shown in this and associated drawings.
- 11 The installation shall preclude intermingling between the intrinsically safe wiring and non-intrinsically safe wiring.
- 12 For information on each unit refer to associated specific drawing for that unit.
- 13 Radio transmitters and receivers used in conjunction with this system do not form part of the certified system and must be separately approved.
- 14 WARNING - Any changes in the intrinsically safe circuits or components may result in an unsafe condition.

SAFE AREA
See Note 1

HAZARDOUS AREA

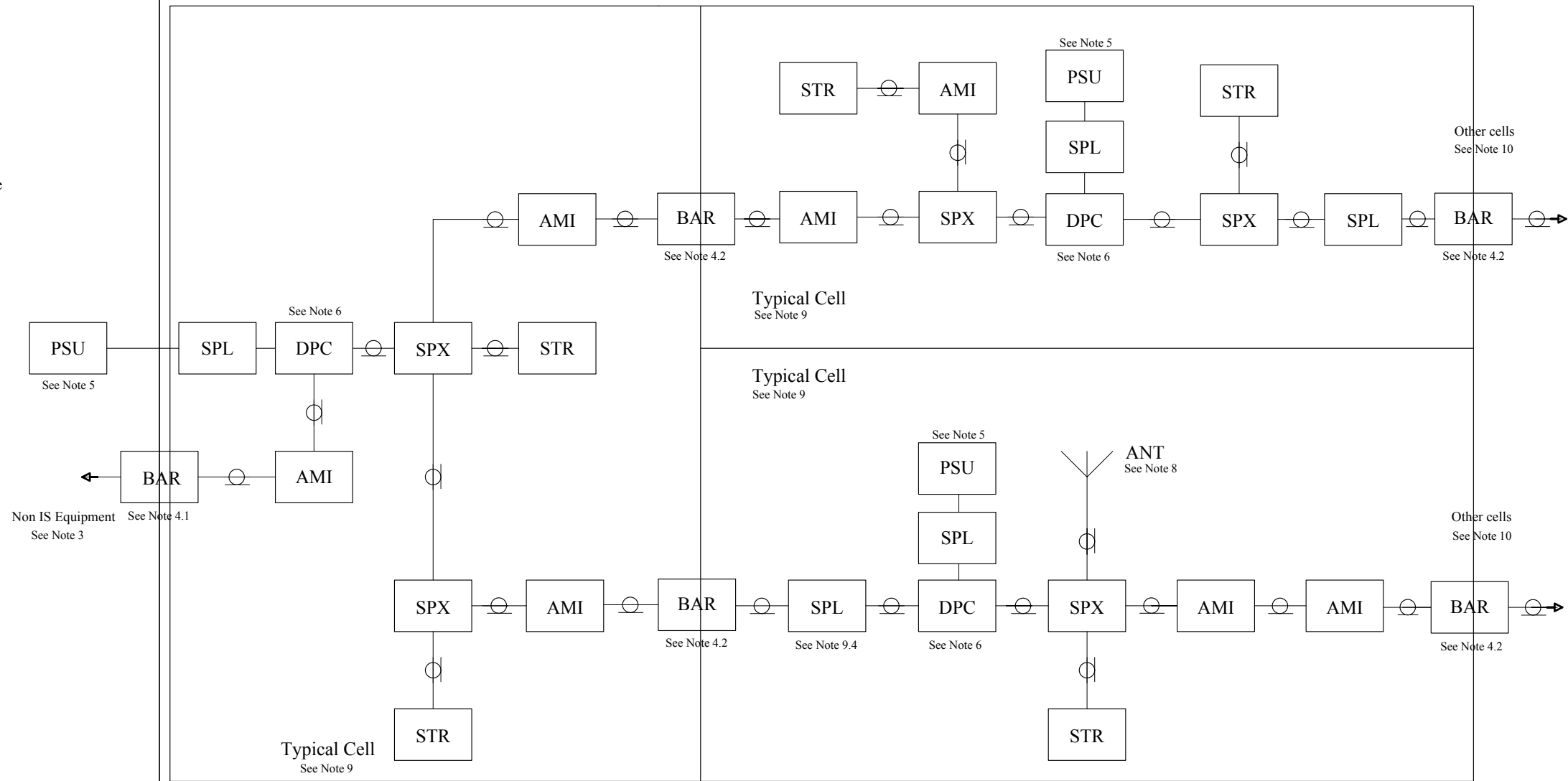

DO NOT CHANGE
WITHOUT
APPROVAL OF
MSHA

Rev.	Description	Date	Drawn	Appr.
Q	Note 3: Updating battery backup to 24hrs.	17-Oct-11	A Masuskapoe	A Masuskapoe
P	Note 7: Changing L/R for LF cable. Note 9: Reducing Max amps per cell to 9.	17-Oct-11	A Masuskapoe	A Masuskapoe
O	Note 7: Updating L/R for LF cable.	23-Sep-11	A Masuskapoe	A Masuskapoe
N	Note 7: Adding minimum LF cable length.	12-Sep-11	A Masuskapoe	A Masuskapoe
M	Note 7: Adding LF cable details.	16-Jun-11	A Masuskapoe	A Masuskapoe
L	Note 6, 9.1: Added SPL. Added SPL to layout.	11-Sept-09	A Masuskapoe	A Masuskapoe
K	Note 7, Removing L/R and capacitance.	18-Aug-09	A Masuskapoe	A Masuskapoe
J	Note 5, PSU in Fresh Air. Note 7, specify LF part #'s.	19-May-09	A Masuskapoe	M.Ward
I	Document title change for product branding	05-Feb-09	A Masuskapoe	A Masuskapoe
H	Note 7, max cable capacitance, L/R change	14-Oct-08	A Masuskapoe	M.Ward
G	LF cable length, transformer note changes	14-Oct-05	A Masuskapoe	M.Ward
F	Input Entity, cable capacitance	01-Apr-05	A Masuskapoe	M.Ward
E	Added SPL, SPL note 9.4	02-Feb-05	A Masuskapoe	M.Ward
D	Note changes	17-Aug-04	A Masuskapoe	M.Ward
C	Note changes	28-May-04	RJ Parsons	M.Ward
B	BAR to isolate cells	20-Oct-03	RJ Parsons	M.Ward
A	New Drawing	29-May-03	RJ Parsons	M.Ward

TITLE Smart Com 150IS Leaky Feeder System Layout		
SHEET 1 of 2	DRAWN BY M.Ward	DATE 5/29/03
CAD FILE NAME MSHA-IS-01		Varis Mine Technology Ltd.